

# HISTORIC AMERICAN TIMBER JOINERY

## A Graphic Guide

### IV. Wall and Brace Joints

*THIS article is fourth in a series of six to discuss and illustrate the joints in American traditional timber-framed buildings of the past, showing common examples with variations as well as a few interesting regional deviations. The series was developed under a grant from the National Park Service and the National Center for Preservation Technology and Training. Its contents are solely the responsibility of the author and do not represent the official position of the NPS or the NCPTT. Previous articles, which appeared consecutively in TF 55-57, covered Tying Joints: Tie below Plate, Tying Joints: Tie at Plate, and Sill and Floor Joints. The remaining articles in the series will cover Roof Joinery and Scarf Joints.*

**W**ALL JOINERY: HORIZONTAL SHEATHING. When a timber-framed building was sheathed horizontally, typically with clapboards, the supporting framework provided vertical nailers called studs, spaced according to the type of sheathing applied. We may find studs centered as closely as 16 in. for ½-in. clapboards or as far apart as 5 ft. on Dutch barns, where the clapboards might be 1x14 lapped boards.

The barefaced mortise and tenon joint typically secures studs to sill, girt, tie beam and plate. Since a barefaced tenon has only a single shoulder, it is very quick to cut. In a scribe rule building, these studs are not usually housed into the mortised piece. In a square rule building, they are typically housed at one or both ends (Fig. 1).

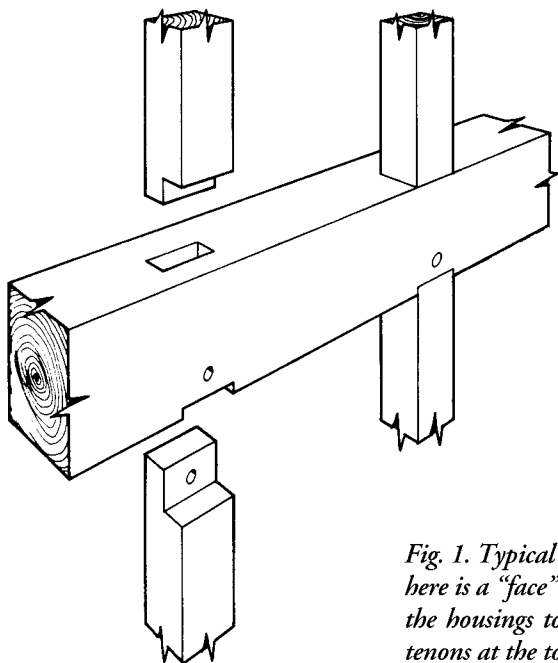

*Fig. 1. Typical barefaced tenon wall studs in a square rule building. The top surface of the girt here is a "face" (a reference surface) and thus has no housings. The lower surface is reduced at the housings to the size of the ideal-timber-within. It is common for studs to have pinned tenons at the top end and stub tenons at the bottom.*



*Photos and drawings Jack A. Sobon*  
*Sheathing direction determines the orientation of wall framing. This early 1800s barn (now dismantled) from Middleburg, N.Y., has studs to support wide clapboards. Note how the braces take precedence over the studs.*

If pinned, tenons are typically twice as long as they are thick (for example, a 1½-in. tenon would be 3 in. long). Unpinned joints are common, as are stub tenons. Stub tenons are the same length as their thickness. Square rule buildings typically have stub tenons at the bottom of studs and pinned tenons at the top, to keep the studs from falling out during the rearing of assemblies but to allow easy insertion of the many studs into the sill mortises as a bent or wall approaches vertical.

The most common stud sizes were 3x4 and 4x4. The 3x4 could be framed flat to the wall with a 1½-in. shoulder and a 1½-in. tenon, or turned on edge for a 2-in. shoulder and a 2-in. tenon. Four by fours were typically framed with a 2-in. shoulder and a 2-in. tenon. In some larger public buildings where the framing was concealed, the studs were as wide as the principal posts so that the interior walls had no protrusions (facing page, Fig. 2). Studs were commonly 6, 7, or 8 in. wide and from 2 to 4 in. thick in such structures. Obviously the barefaced tenon wouldn't work here.

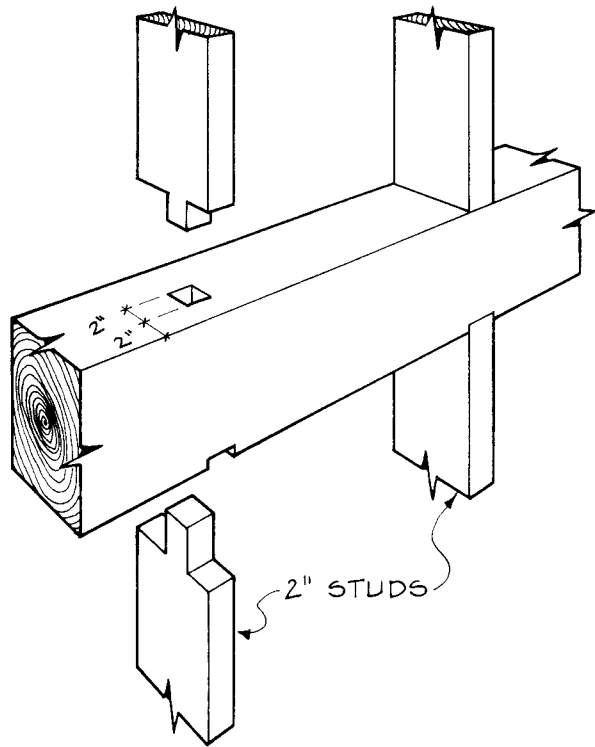

Fig. 2. In churches where the framing was concealed by plaster, studding was commonly as wide as the main timbers, to present a flush appearance on the interior. Here, 2x8 studs are framed by the square rule. Two-in. studs are rarely pinned and occasionally nailed. Tenons on 2-in. stock are quickly sawn out. The mortises require just a single bore.

Where a stud met a brace or rafter, it was rarely mortised in. The stud would be fitted after the frame was reared. Typically it was butted and nailed (Fig. 3). A less common but stronger solution was to use a beveled lap joint (Fig. 4). It too was secured with nails.

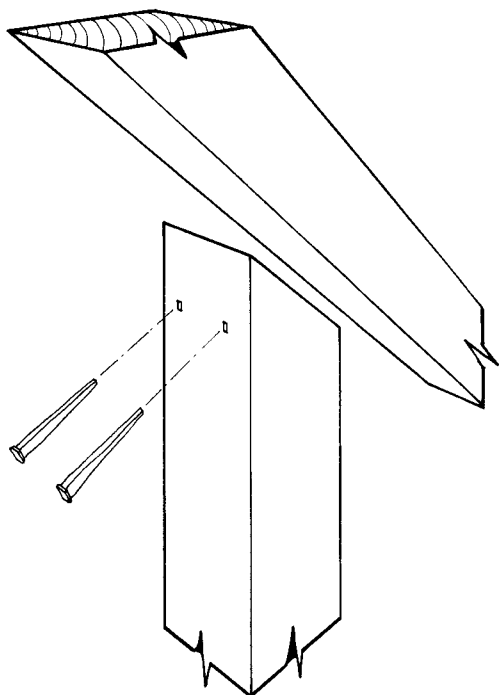
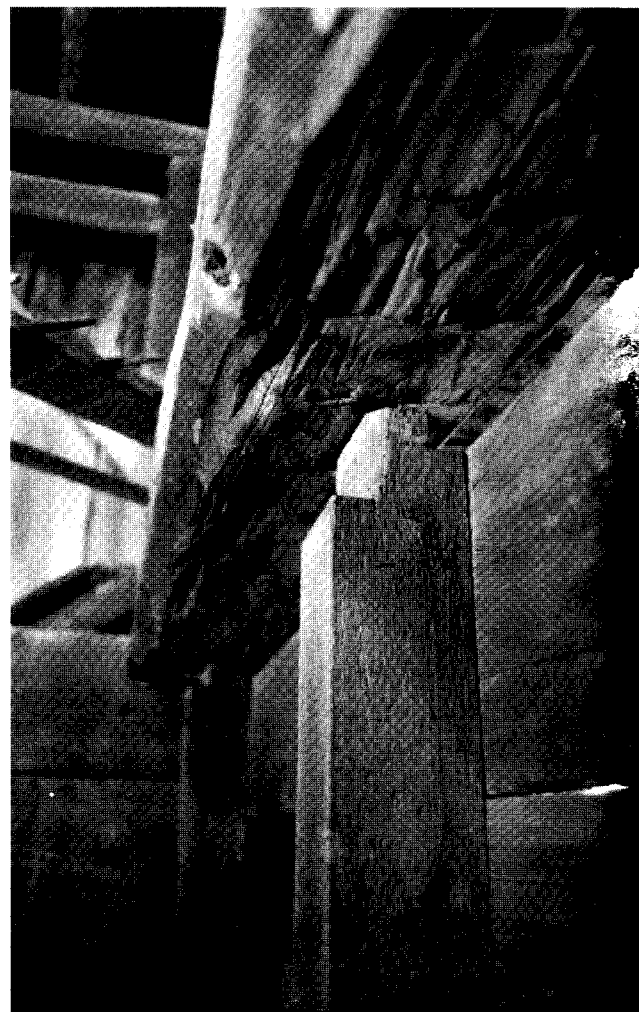

Fig. 3. Studs are subservient to braces (which must be uninterrupted to do their work well) and consequently are merely cut to match the angle and secured with nails. However, the other end of such studs is still tenoned.



This partially withdrawn stud in a barn in Shaftsbury, Vermont, was relieved at its end to make its tenon barefaced. Uncommonly, the relief cut was not angled, and gives the appearance of a second cheek and shoulder.

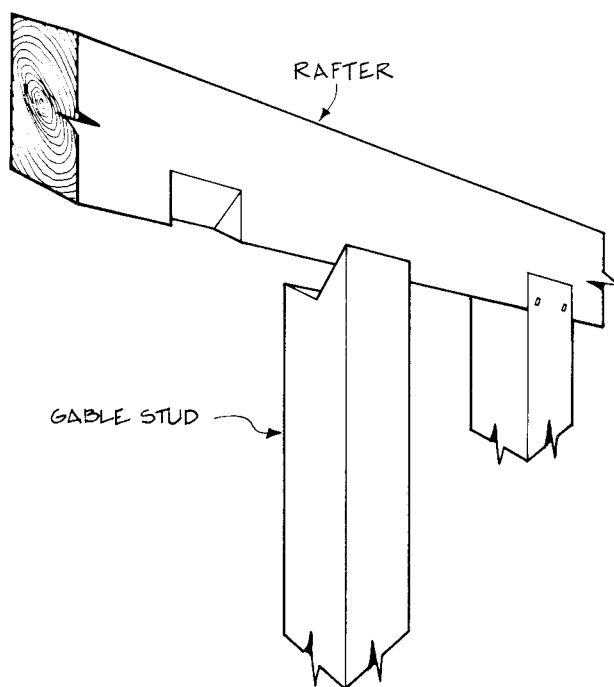

Fig. 4. A beveled lap provides a sound solution to inserting studs after erection. It is a joint easily fashioned in situ.

**WALL JOINERY FOR VERTICAL SHEATHING.** When buildings are sheathed vertically, horizontal girts are framed in for support. In barns, where girts are mostly found, these are spaced from 2 to 6 ft. apart. In plank houses where the walls are sheathed in thicker planks, the girts occur only at the floor levels.

Girt joinery closely resembles stud joinery. The barefaced tenon is common, as are the sizes 3x4 and 4x4 (Fig. 5). Many barns built before the advent of the circular sawmill used girts hewn on only one face and squared up to a consistent size only at the joints (Fig. 6). For girts with longer spans or with floor loads to support as well, a standard mortise and tenon replaced the barefaced tenon (Fig. 7).

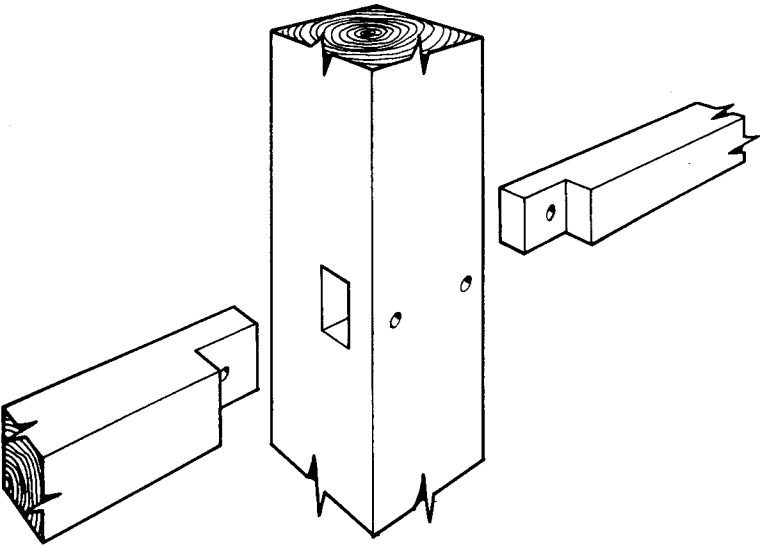

Fig. 5. Barefaced and pinned girts in a typical scribe rule building.

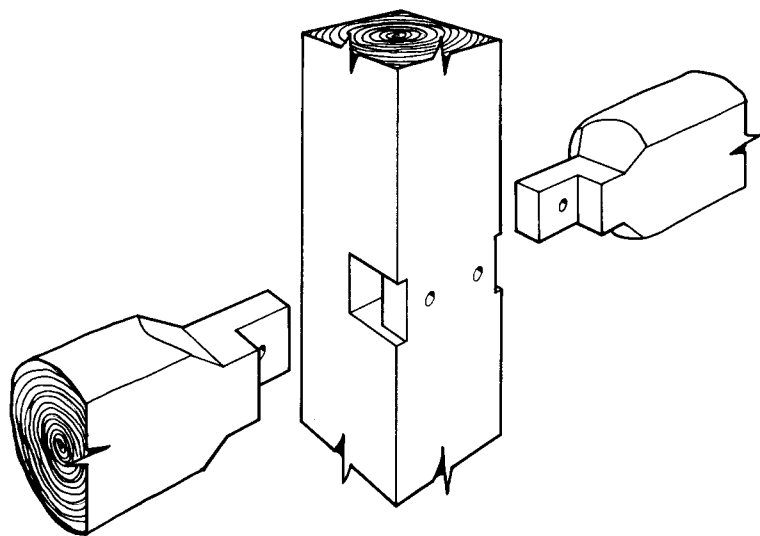

Fig. 6. Barefaced and pinned girts in a typical square rule building. To save on hewing, these members were flattened only on the face receiving the wall sheathing. The ends are squared up at the joint. The post has its ideal-timber-within centered so the girts are housed both sides.

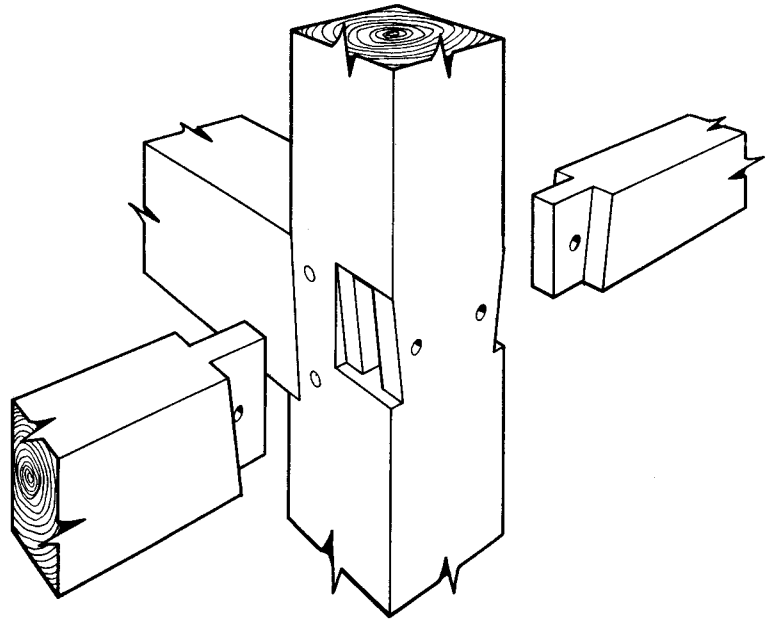

Fig. 7. Wall girts at floor level in a scribe rule building. These load-bearing girts rely on standard mortise and tenon joints with diminished bearing shoulders.

**BRACE JOINERY.** Few timber-framed buildings were built without diagonal bracing. In the era before plywood sheathing, braces conferred a measure of rigidity to frames and prevented distortion from wind and seismic loads. They can function in compression, tension or both, but braces are counted upon to act primarily in compression and consequently occur in opposing pairs. Many surviving barns have unpinned, stub-tenoned braces, proving the latter's compression-only function. Lap-dovetailed braces, found typically in Dutch barns, appear by their shape to be able to handle tensile loads as well.

**Tenoned Braces.** The vast majority of tenoned braces are barefaced, as with studs and girts. Braces in frames built using the earlier scribe rule system might have no bearing shoulder (Fig. 8, left) or a diminished bearing shoulder (Fig. 8, right). The latter configuration is clearly superior, adding to the tenon end an addi-

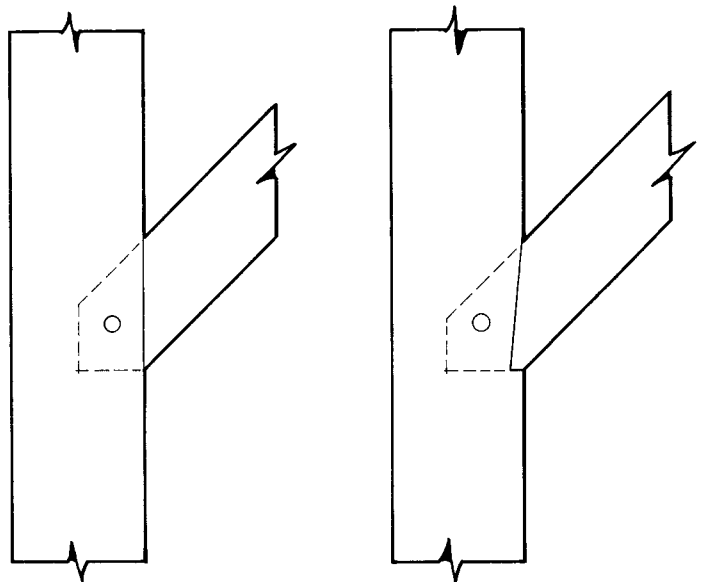

Fig. 8. Scribe rule braces: non-bearing shoulder on the left, diminished bearing shoulder on the right.

